

CAPACITY	SYMBOL/SERIAL NO.	CIRCUIT DIAGRAM
AC100-240V, 50/60Hz		
28W		

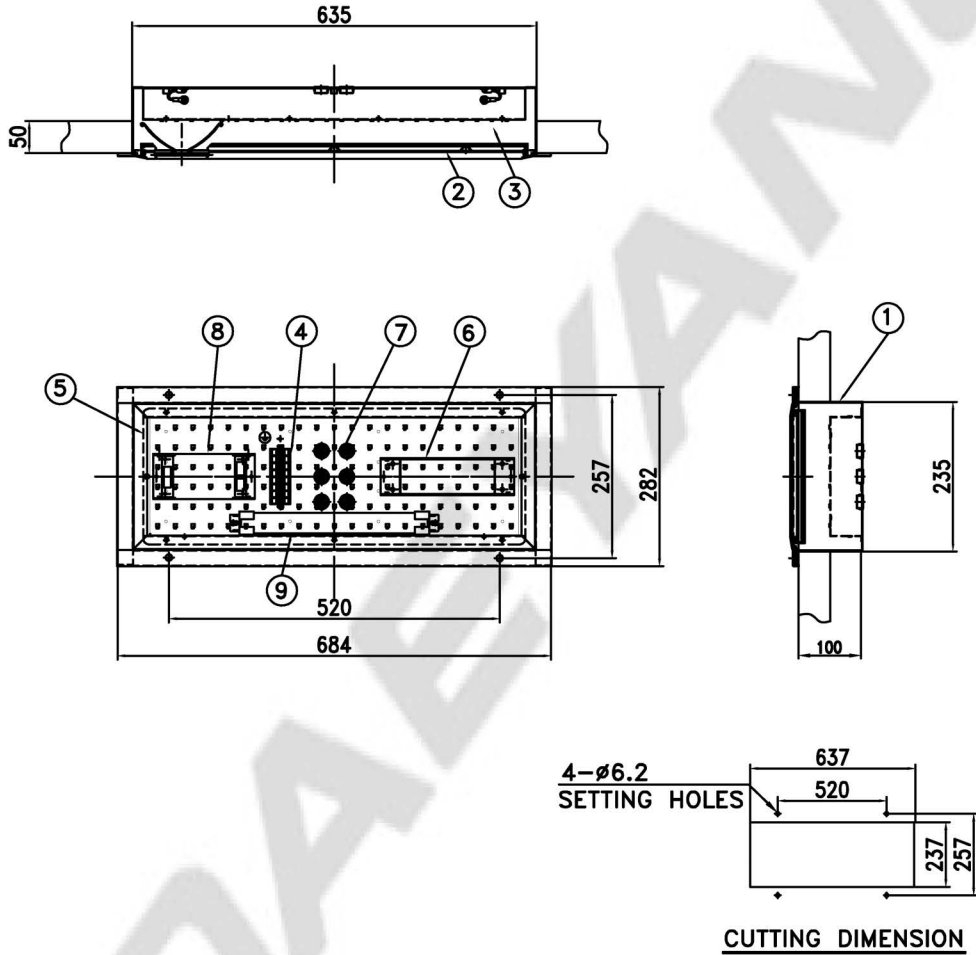

					5	LED module BRACKET	STEEL	1	
9	BATTERY	-	1		4	TERMINAL BLOCK	-	1	CLAMPING 8P
8	EMERGENCY LED driver	-	1		3	LED module	-	1	5,000K
7	CABLE INLET HOLES	NYLON	6	ø16 SNAP BUSHING	2	GLOBE	ACRYL	1	
6	LED driver	-	1		1	BODY	STEEL	1	
NO	NAME OF PARTS	MATERIAL	Q'TY	REMARKS	NO	NAME OF PARTS	MATERIAL	Q'TY	REMARKS

APPROVED	B. K. KIM	UNIT	MM	TITLE; NO-GAP LED CEILING LIGHT (BATTERY BACKUP) FOR MARINE USE			
CHECKED		SCALE	N/S				
DRAWING	B. I. KIM	COLOR	N-9.3				
DATE	2015.12.04	IP	20				
				MODEL NO.	LEB128NF-0550SNQC50B-A	WEIGHT	8 Kg
				DWG NO.	L0115	SHEET NO.	